

**Subject**  
**OB25132 Demo Board Manual**

Board Model: CH5V0.7A 25132\_1538

Doc. No.: OB\_DOC\_DBM\_2513202



**Key features:**

- Standby power less than 50mW@264Vac
- Precise CV/CC regulation
- Primary-side sensing and regulation without TL431 and opto-coupler
- Cost effective and simplified system design
- Average efficiency meet DOE/COC
- Integrated BJT Switch
- No RCD and output diode RC snubber
- No X & Y design
- Audio noised free operation
- Meet EN55022 EMI

**Schematic:**

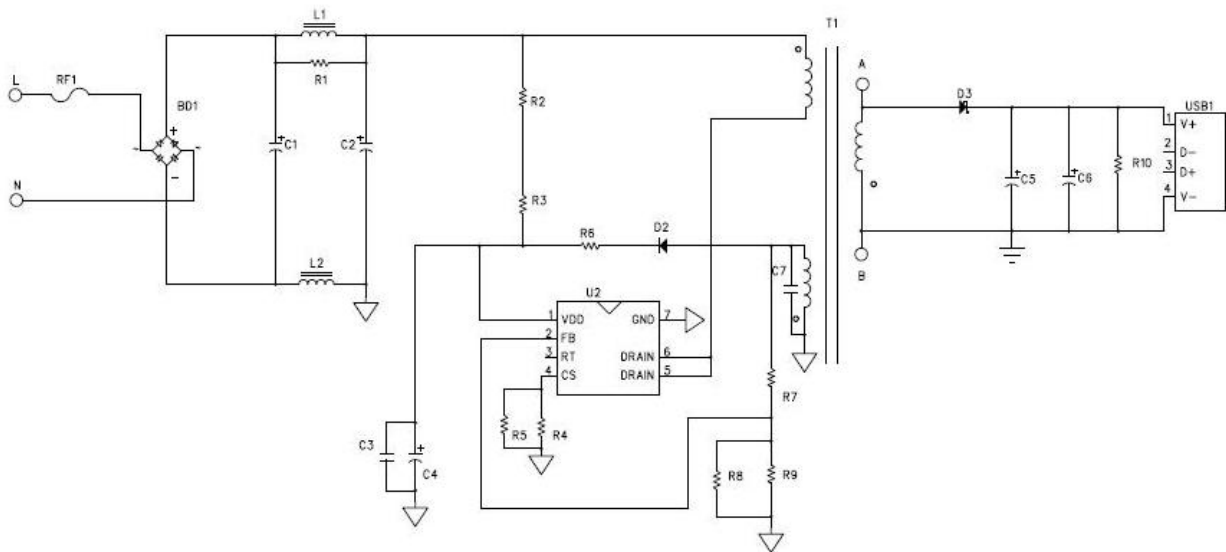

## Performance Evaluation

This session presents the test results of OB25132 module up to date. Results on inrush current and safety test are not included and will be added when they become available.

Overall, the module meets design specifications. All data was measured at the end of 1.5m, 26AWG output cable.

### Performance Highlights

- Standby power less than 75mW@264V
- Precise CV/CC regulation
- The average efficiency meet DOE Level 6/COC
- EMI passed EN55022 and FCC15 Class B test with more than 6dB margin

### System Electrical Specification

Description		Symbol	Min	Typ	Max	Units	Comment	
<b>Input Section</b>								
Input Voltage		$V_{IN}$	90		264	V	2 Wire	
Line Frequency		$f_{LINE}$	47	50/60	63	Hz		
Standby Power					75	mW	230V	
<b>Output characteristics</b>								
CV Section	Output Voltage	$V_{OUT\_CV}$	4.75		5.25	V		
	Output Current	$I_{OUT\_CV}$	0		0.7	A		
CC Section	Output Voltage	$V_{OUT\_CC}$	2.0			V		
	Output Current	$I_{OUT\_CC}$	0.77		0.91	A		
Ripple & Noise		$V_{RIPPLE}$			80	mV <sub>P-P</sub>		
Continuous Output Power		$P_{OUT}$		3.5W				
Over Current Protection		$I_{OUT\_MAX}$			0.91	A		
Active Mode Efficiency		$\eta$	70.96/ 61.80			%	Measured at Line End, $V_{IN}=115V/230V$	
<b>Time sequence</b>								
Turn on delay time					2	s		
<b>Environmental</b>								
Conducted/Radiation EMI		Meets EN55022B\FCC 15						
Safety		Meets IEC950,UL1950,Class II						
ESD			8/15			kV		

### Test Equipments

Item	Vender	Module
AC Source	WEST	WEW1010
Digital Power Meter	YOKOGAWA	WT210
Electrical Load	Chroma	63030
Oscilloscope	LeCroy	WS424
Multimeter	VICTORY	VC9807A

# 1. Input Characteristics

## 1.1 Standby power

Table. 1 Standby power

Input voltage	Pin(mW)	Vo(V)	Specification	Test result
90V/60HZ	15.3	5.035	<75mW	Pass
115V/60HZ	16.6	5.034		
230V/50HZ	29.6	5.03		
264V/50HZ	36.8	5.027		

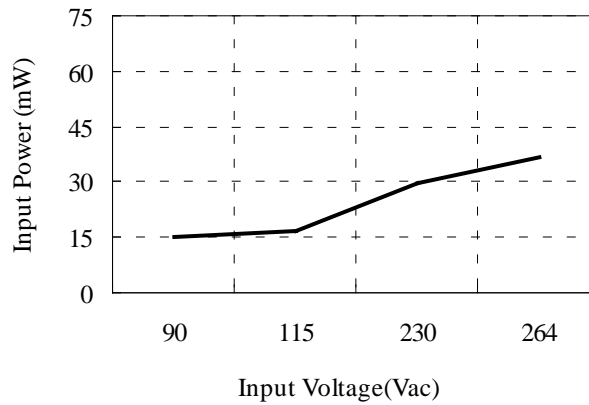

Fig. 1 Standby Power vs. Input Voltage

## 1.2 Efficiency

Table. 2 Efficiency Line end with 26AWG, 1.5m (402mΩ) output line.

Input voltage	10%	25%	50%	75%	100%	25%~100% Load Aver. Eff.	Standards		Test Result
							DOE	COC	
115V/60Hz	73.99%	76.26%	75.18%	73.91%	73.00%	74.59%	70.86%	61.80% (10%Load)	Pass
230V/50Hz	67.45%	72.79%	73.15%	72.47%	71.77%	72.55%			

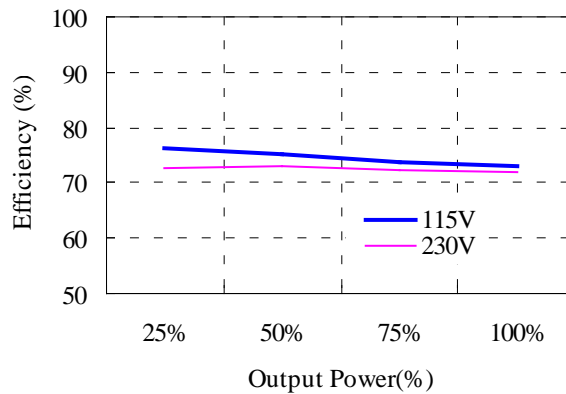

Fig. 2 Efficiency vs. Percent of Rated Output Power

### 1.3I-V Curve

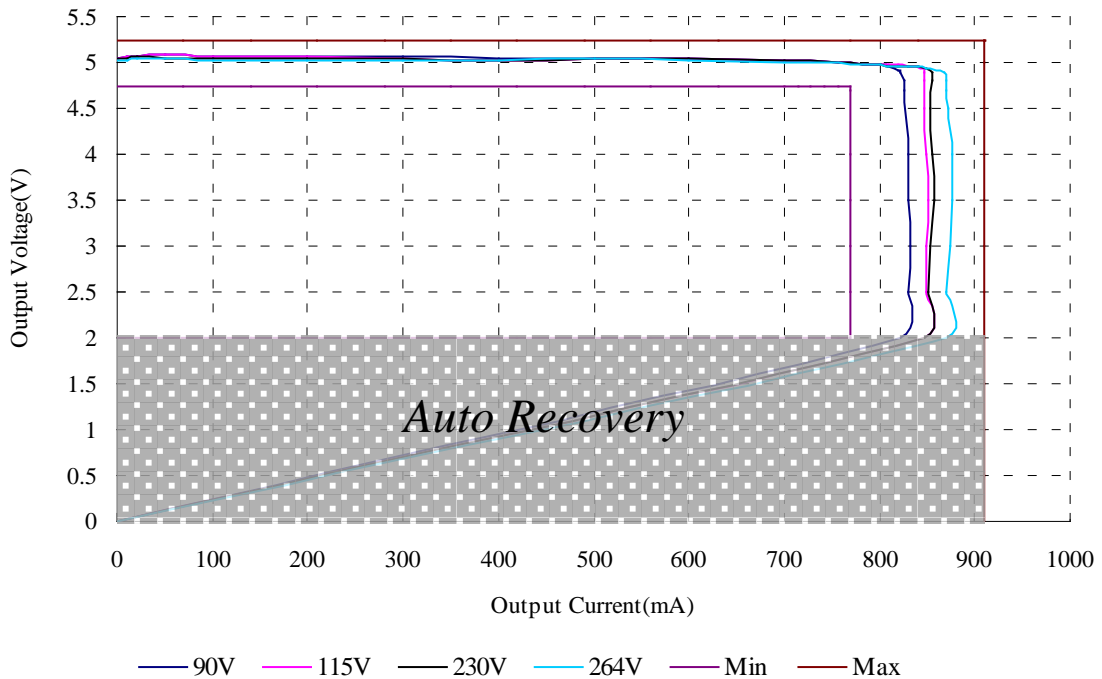

Fig. 3 I-V Curve

## 2 Output Characteristics

### 2.1 Line Regulation & Load Regulation

Table. 3 Line Regulation & Load Regulation

Input voltage	No load(V)	Half load(V)	Full load(V)	Specification(V)	Test result
90V/60Hz	5.035	5.040	5.015	4.75-5.25	<b>Pass</b>
115V/60Hz	5.035	5.038	5.013	4.75-5.25	
230V/50Hz	5.031	5.028	5.012	4.75-5.25	
264V/50Hz	5.027	5.015	5.000	4.75-5.25	
Line Regulation	±0.25%			< ±2%	<b>Pass</b>
Load Regulation	±0.19%			< ±5%	<b>Pass</b>

### 2.2 Ripple & Noise

Table. 4 Ripple & Noise

Input voltage	R&N (mV)		Remark
	No load	Full load	
90V/60Hz	19	72	Fig. 4,5
115V/60Hz	20	66	
230V/50Hz	20	67	
264V/50Hz	22	69	Fig. 6,7

Note: Ripple& noise was measured at line end with probe cap and ground clip. Measurement bandwidth was limited to 20MHz.

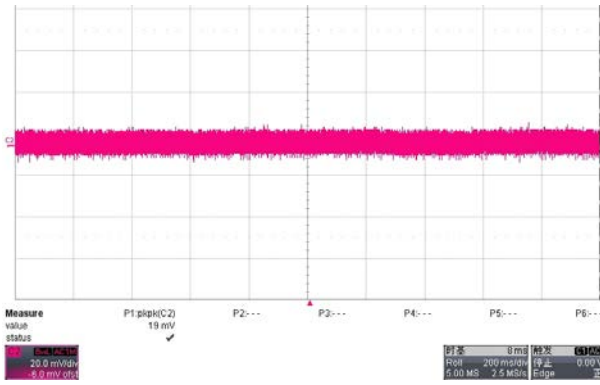

Fig. 4 Measured ripple& noise waveform@90V/60Hz, no load

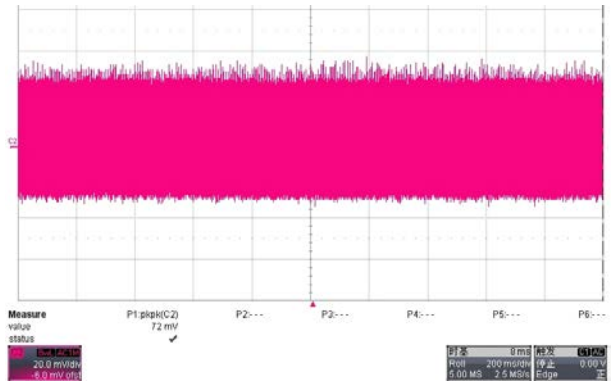

Fig. 5 Measured ripple& noise waveform@90V/60Hz, full load

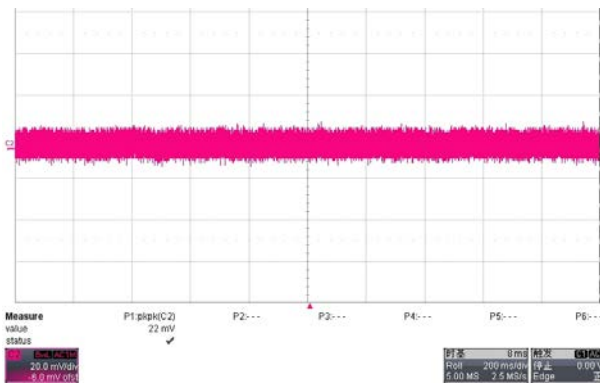

Fig. 6 Measured ripple& noise waveform@264V/50Hz, no load

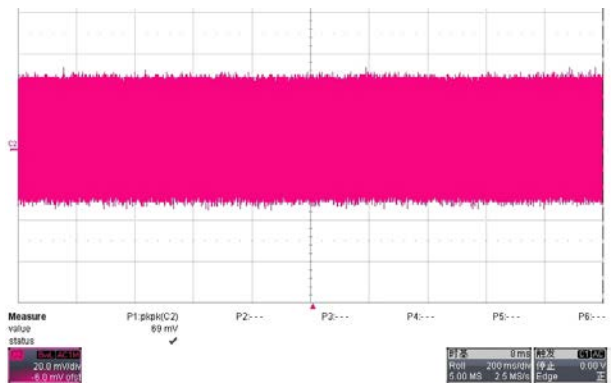

Fig. 7 Measured ripple& noise waveform@264V/50Hz, full load

## 2.3 Dynamic Test

A dynamic loading with low load lasting for 50ms/20ms and high load lasting for 50ms/20ms is added to output. The high load is 0.35A and the low load is 0A. The ramp is set at 0.125A/ $\mu$ s at transient. Measurement was taken at line end (Same as R&N measurement)

Table. 5 Output voltage under dynamic test(0.35A lasting for 50ms, 0A lasting for 50ms)

Input	Vomin-Vomax(v)	Remark
90V/60Hz	5.59~4.02	
115V/60Hz	5.59~4.09	
230V/50Hz	5.65~4.31	
264V/50Hz	5.65~4.05	

(0.35A lasting for 20ms, 0A lasting for 20ms)

Input	Vomin-Vomax(v)	Remark
90V/60Hz	5.53~4.73	
115V/60Hz	5.56~4.73	
230V/50Hz	5.59~4.66	
264V/50Hz	5.62~4.60	

## 2. EMI Test

The Power supply passed EN55022 Class B EMI requirement with more than 6dB margin

### 2.1 Conducted EMI Test

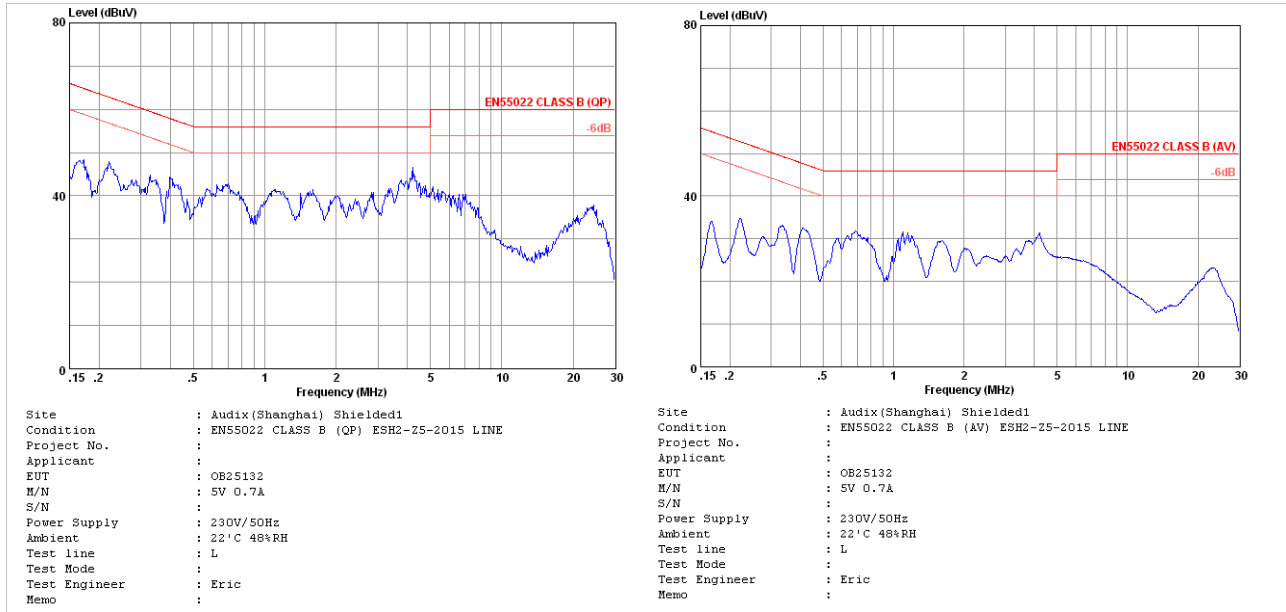

### 2.2 Radiation EMI Test

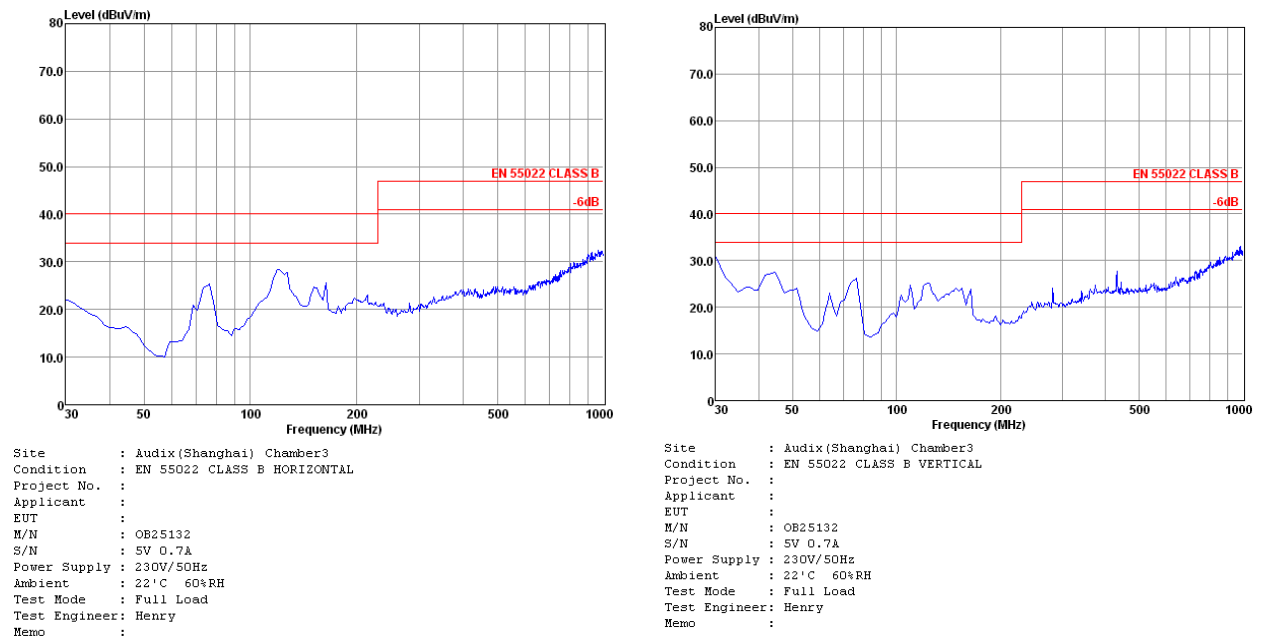

## **Disclaimer**

On-Bright Electronics reserves the right to make corrections, modifications, enhancements, improvements, and other changes to its documents, products and services at any time and to discontinue any product or service without notice. Customers should obtain the latest relevant information before placing orders and should verify that such information is current and complete.

This document is under copy right protection. None of any part of document could be reproduced, modified without prior written approval from On-Bright Electronics.