

Subject
OB6220R Demo Board Manual

Board Model: AUOB6220R-28 1319
 Doc. No.: OB_DOC_DBM_A_6220R00

Description:

The OB6220R Demo Board consists of a stereo 13W Bridge Tied Load (BTL) output, fixed 26dB gain, class-D, audio power amplifier that completed with a small number of external components mounted on a printed circuit board. It can be used to directly drive speakers with an external analog audio source as the input. The audio application of 2 channels single ended and differential inputs are presented. For the application that short traces and wires from output pins to speaker, a simple ferrite beads filter to replace LC filter can be selected. The detailed features, block diagram, schematics, BOM, PCB layout, application notes and test data are described.

Key Features:

- Stereo 13W BTL output into 8Ω load at 15Vcc
- Stereo 10W BTL output into 8Ω load at 13Vcc
- Stereo 8.8W BTL output into 8Ω load at 12Vcc
- 87% efficiency(driving 8Ω load@12Vcc)
- Fixed 26dB gain
- Excellent EMC performance, output ferrite beads filter can be used to replace LC filter

Revision History

Revise Date	Version	Reason/Issue
2013-10-11	00	First Issue

Contents

1. Features	3
2. Demo Board Specifications	3
3. Application Reference	4
3.1 Demo Board Block Diagram	4
3.2 Terminal & Switch & Jack	5
3.2.1 Terminal & Switch & Jack Assignment.....	5
3.2.2 Switch & Jumper Setting.....	5
3.3 Schematic	6
3.4 Operation	7
3.4.1 Quick Start List for Stand-Alone Operation	7
3.4.2 Power Supply	7
3.4.3 Audio Inputs and Outputs.....	7
3.4.4 Control Inputs.....	7
3.4.5 Power Up	7
3.5 PCB layout	8
3.6 Bill of Material	9
3.7 EMC Report	10
3.7.1 Conducted Emission Test	10
3.7.2 Radiation Emission Test.....	11
3.8 Protection Report	12
3.8.1 Protection Test – OVP,UVP,OTP.....	12
3.8.2 Protection Test – Output Short Circuit Protection	12
3.9 Reliability Report	14
3.9.1 Abnormal Power On Test	14
3.9.2 High Temperature System Burn-in Test	14
3.9.3 Low Temperature Cycle Power on-off Test	14
3.9.4 Maximum Output Power Burn-in Test	14

1. Features

- Stereo 13W BTL output into 8Ω load at 15Vcc
- Stereo 10W BTL output into 8Ω load at 13Vcc
- Stereo 8.8W BTL output into 8Ω load at 12Vcc
- 6V to 20V single-supply operation
- Can drive stereo speakers as low as 4Ω
- 87% efficiency(driving 8Ω load@12Vcc)
- Up to 93dB SNR
- Low quiescent current 8mA
- Fixed 26dB gain (no external components required)
- Internal oscillator (no external components required)
- External shutdown control function
- Perfect OVP/UVP/OTP/Output Short Circuit protection with recovery
- Speaker protection circuitry includes DC detect function
- Minimized pop noise
- Eliminates the need of external heat sink
- Space-saving surface mount 28-Pin TSSOP/PP high power package
- Excellent EMC performance, Meet EN55022-ClassB EMC standard

2. Demo Board Specifications

Symbol	Item	Specification
Vcc	Supply Voltage range	6V to 20V
Icc	Supply current	3A max
Po	Continuous output power per channel: 8 Ω, VCC = 12 V, THD+N = 10%,BTL	8.8W
	Continuous output power per channel: 8 Ω, VCC = 13 V, THD+N = 10%,BTL	10 W
	Continuous output power per channel: 8 Ω, VCC = 15 V, THD+N = 10%,BTL	13W
RI	Minimum load impedance	4 Ω
Vin	Input amplitude range	0~2Vrms

3. Application Reference

3.1 Demo Board Block Diagram

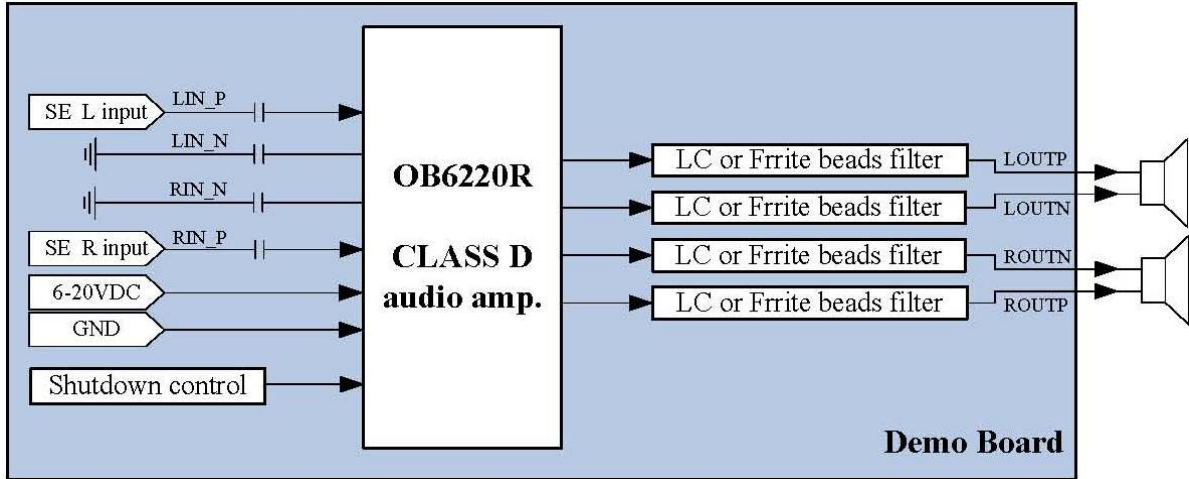

Fig. 1 Stereo Class-D Amplifier with BTL Output and Single-Ended Inputs

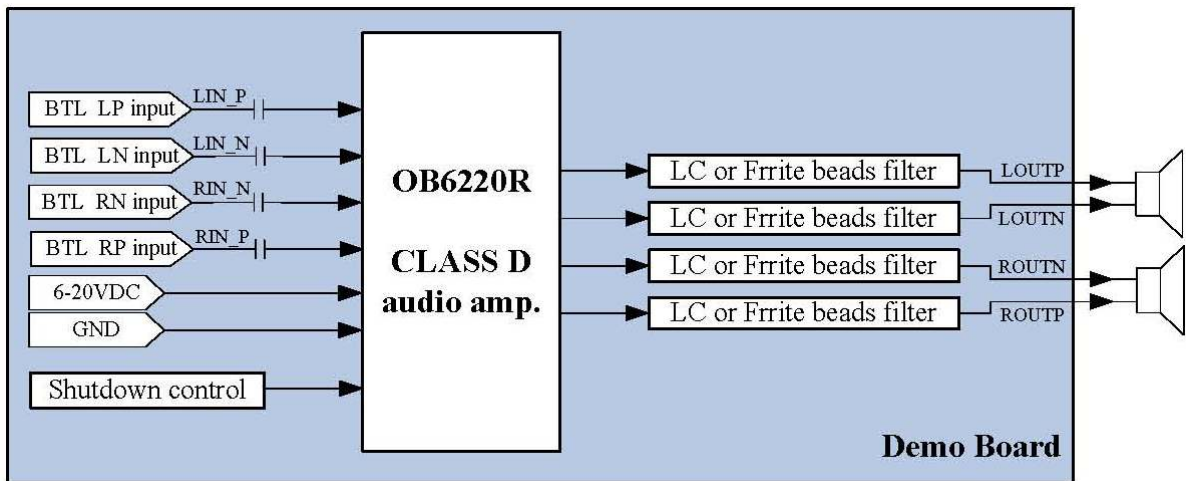

Fig. 2 Stereo Class-D Amplifier with BTL Output and Differential Inputs

3.2 Terminal & Switch & Jack

3.2.1 Terminal & Switch & Jack Assignment

Table 1. Terminal & Switch & Jack Assignment

Reference Number	I/O	Description
VCC	P	Power Supply (6–20VDC)
GND	P	Power Supply ground
LIN	I	Positive and Negative audio input for left channel
RIN	I	Positive and Negative audio input for right channel
LOUT_P	O	Positive audio output for left channel
LOUT_N	O	Negative audio output for left channel
ROUT_P	O	Positive audio output for right channel
ROUT_N	O	Negative audio output for right channel
_SD	-	Shutdown control switch

* About the Terminal&Switch&Jack's position on demo board, please refer to the **3.5 PCB layout** 's view.

3.2.2 Switch & Jumper Setting

Table 2. shutdown setting

State	Jumper	
<i>shutdown</i>	_SD	ON
<i>operation</i>		OFF

3.3 Schematic

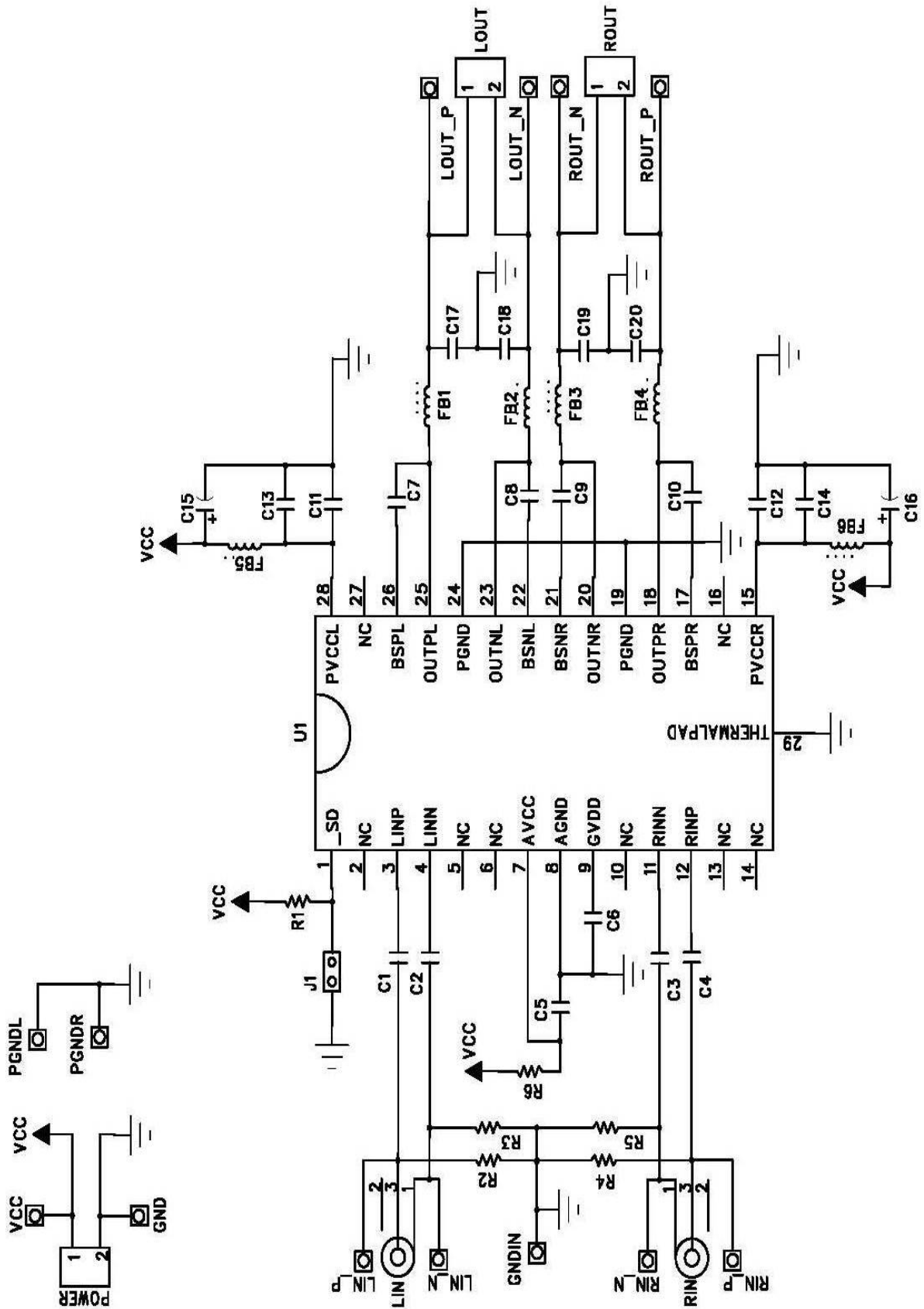

3.4 Operation

3.4.1 Quick Start List for Stand-Alone Operation

Follow these steps to use the OB6220R demo board stand-alone or when connecting it into existing circuits or equipments. Connections to the demo board can be made by using plugs for the power supply and output connections. The audio inputs accept standard RCA plugs. A single power supply is required to power up the demo board. The Vcc supply can also be used to power all the AVCC&PVCC, and can be used to pull up the logic pins for shutdown control. GVDD is an internally generated supply for the output FETs.

3.4.2 Power Supply

1. Ensure that the external power source is set to OFF.
2. Connect an external regulated power supply adjusted from 6V to 20V to the POWER connector with taking care to observe marked polarity.

3.4.3 Audio Inputs and Outputs

1. Connect analog audio source to jacks LIN and RIN using standard RCA plugs, either differential or single-ended. Short the audio input to GND that are not in being used by R2,R3,R4,R5 on demo board.
2. Connect a speaker across terminal LOUT (or terminals LOUTP and LOUTN), connect another speaker across terminal ROUT (or terminals ROUTP and ROUTN).

3.4.4 Control Inputs

1. Ensure the jumper are set correctly depending on the desired **3.2.2 Switch & Jumper Setting**, include _SD state setting.

3.4.5 Power Up

1. Verify correct voltage and input polarity, and turn the external power supply ON. The demo board begins operation
2. Adjust the audio source for the correct volume and enjoy!.

3.5 PCB layout

TOP Side View

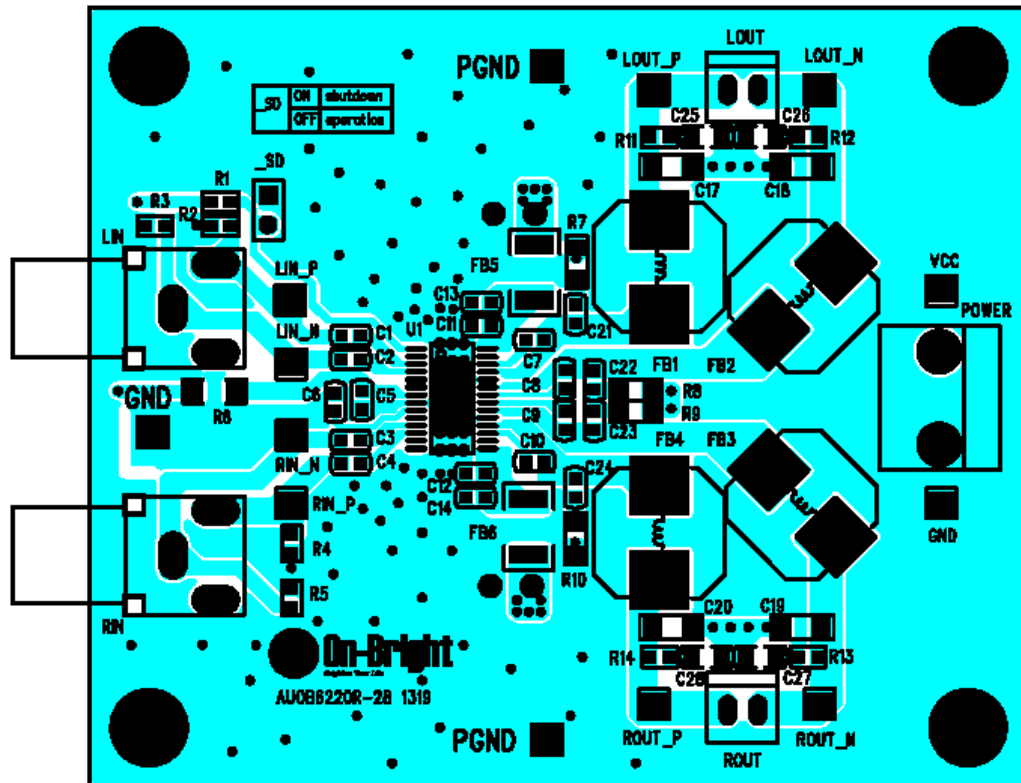

Bottom Side View

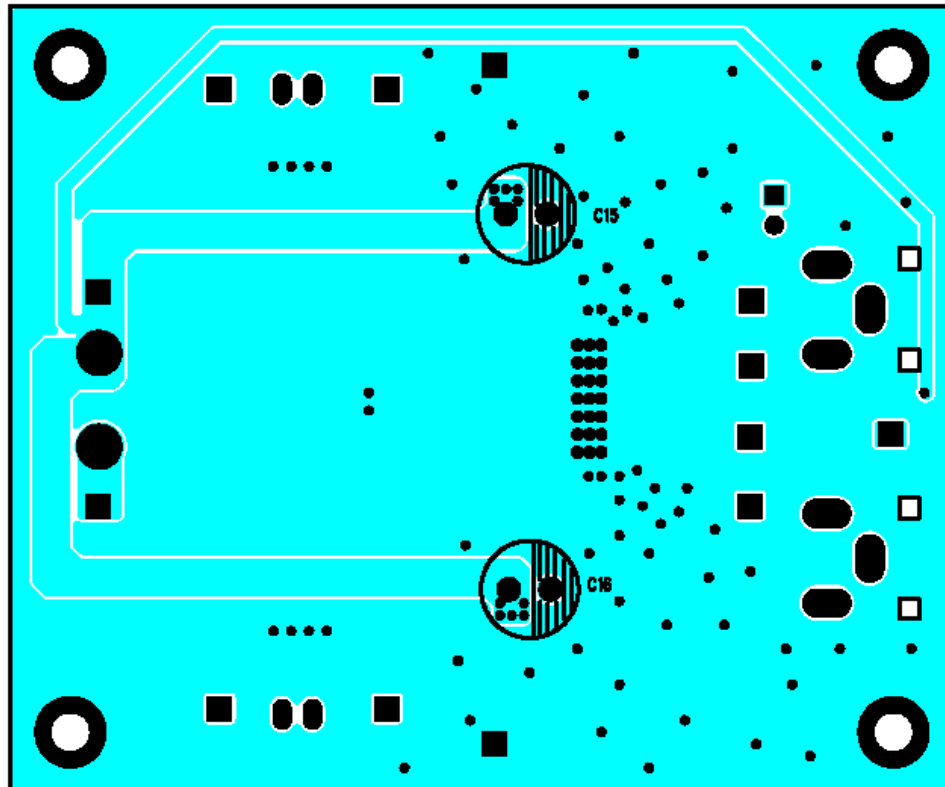

3.6 Bill of Material

Item	Qty.	Ref.No.	Description	Size
ICs:				
1.	1	U1	Class D audio amplifier IC,OB6220R	TSSOP28
PCB:				
2.	1	PCB	OB6220R EVM PCB, double layers, AUOB6220R-28 1319	79*66*1.6mm
Resistor:				
3.	1	R1	Resistor,chip,100kohm,1/10W,5%	0603
4.	1	R6	Resistor,chip,10ohm,1/4W,1%	1206
5.	2	FB5,FB6	Resistor,chip,0ohm,1/2W,5%	1812
Capacitor:				
6.	5	C1,C2,C3,C4,C6	Capacitor,ceramic,1uF,±10%,X5R,16V	0603
7.	1	C5	Capacitor,ceramic,1uF,±10%,X5R,35V	0603
8.	4	C7,C8,C9,C10	Capacitor,ceramic,0.22uF,±10%,X5R,35V	0603
9.	2	C11,C12	Capacitor,ceramic,0.001uF,±10%,COG,35V	0603
10.	2	C13,C14	Capacitor,ceramic,0.1uF,±10%,COG,35V	0603
11.	2	C15,C16	Capacitor,electrolytic,100uF,35V,105°C	Φ7*11mm
12.	4	C17,C18,C19,C20	Capacitor,ceramic,1nF,±5%,X7R,35V	1206
Inductor:				
13.	4	FB1,FB2,FB3,FB4	Ferrite beads,SMD, 60ohm@100MHz, 6A Würth, 742792410	1806
Others:				
14.	1	POWER	Power Connector,2pin,7.9mm,Male	
15.	2	LOUT,ROUT	Connector,2pin,2.54mm,Male	
16.	1	LIN	Phono Jack,PC mount,switched,red	
17.	1	RIN	Phono Jack,PC mount,switched,white	
18.	1	_SD	Jumper,2pin	

For LC filter application to replace ferrite beads filter, change following components on this demo board are needed.

Item	Qty.	Ref.No.	Description	Size
12.	4	C17,C18,C19,C20	Capacitor,ceramic,0.68uF,±5%,X7R,35V	1206
13.	4	FB1,FB2,FB3,FB4	Inductor,SMD,22uH,ferrite material TOKO, DS104C2	10.4*10.4*4.8mm

* All others unlisted components are no assembled.

* All components should be ordered as Lead-Free

3.7 EMC Report

The demo board passed EMC requirement with more than 6dB margin

All following EMC test used OB6220R + OB2273 demo boards.

3.7.1 Conducted Emission Test

EN55022 CLASS B report @ 12Vcc8ohm, stereo 8W, ferrite beads filters
 power line length=1m, input line length=1m, speaker cable length=80cm

AV curve

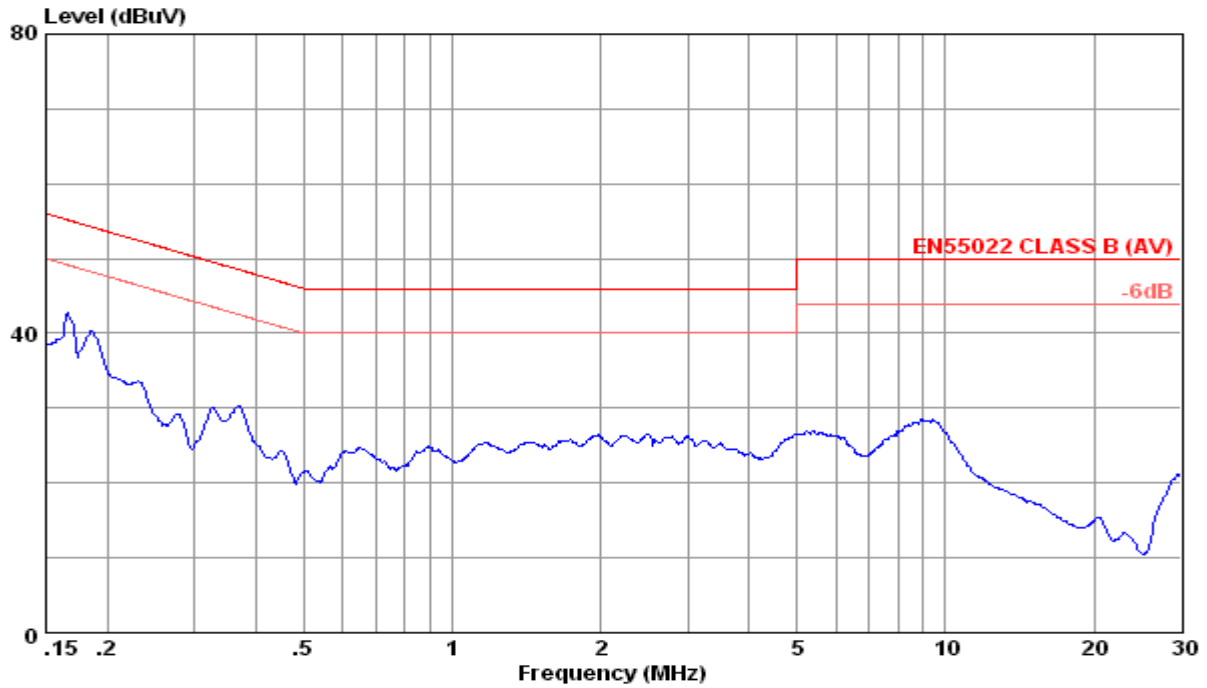

QP curve

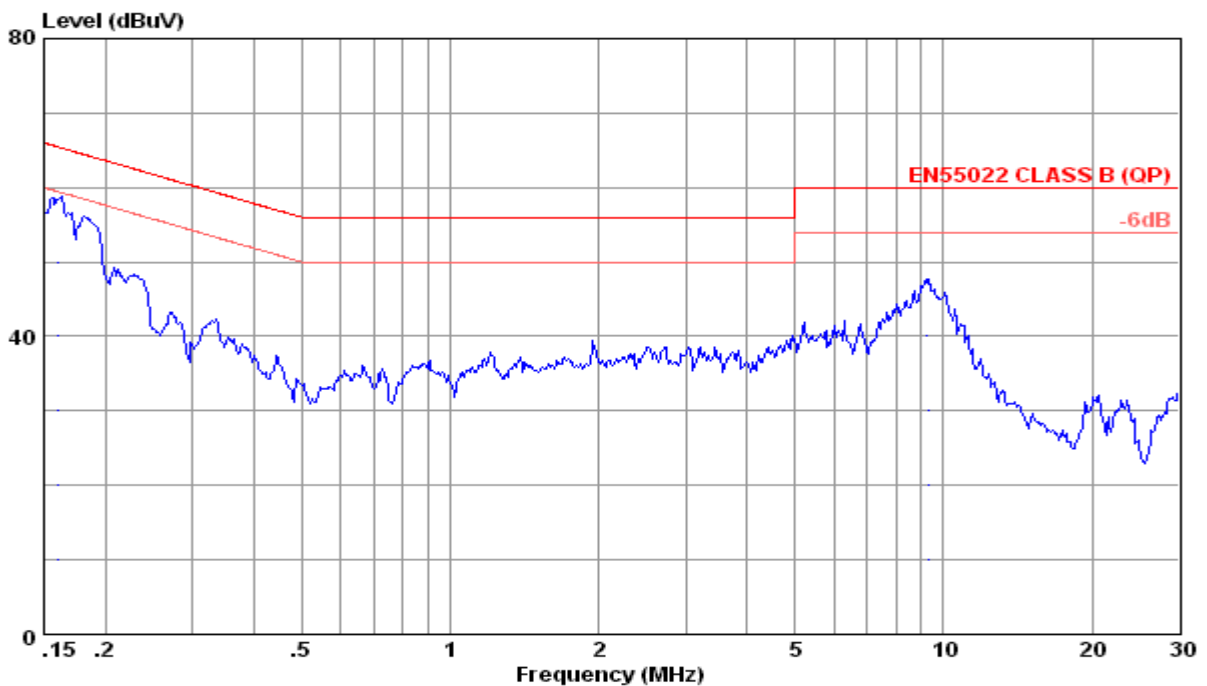

3.7.2 Radiation Emission Test

**EN55022 CLASS B report @ 12Vcc8ohm, stereo 8W, ferrite beads filters
 power line length=1m, input line length=1m, speaker cable length=80cm**

VERTICAL

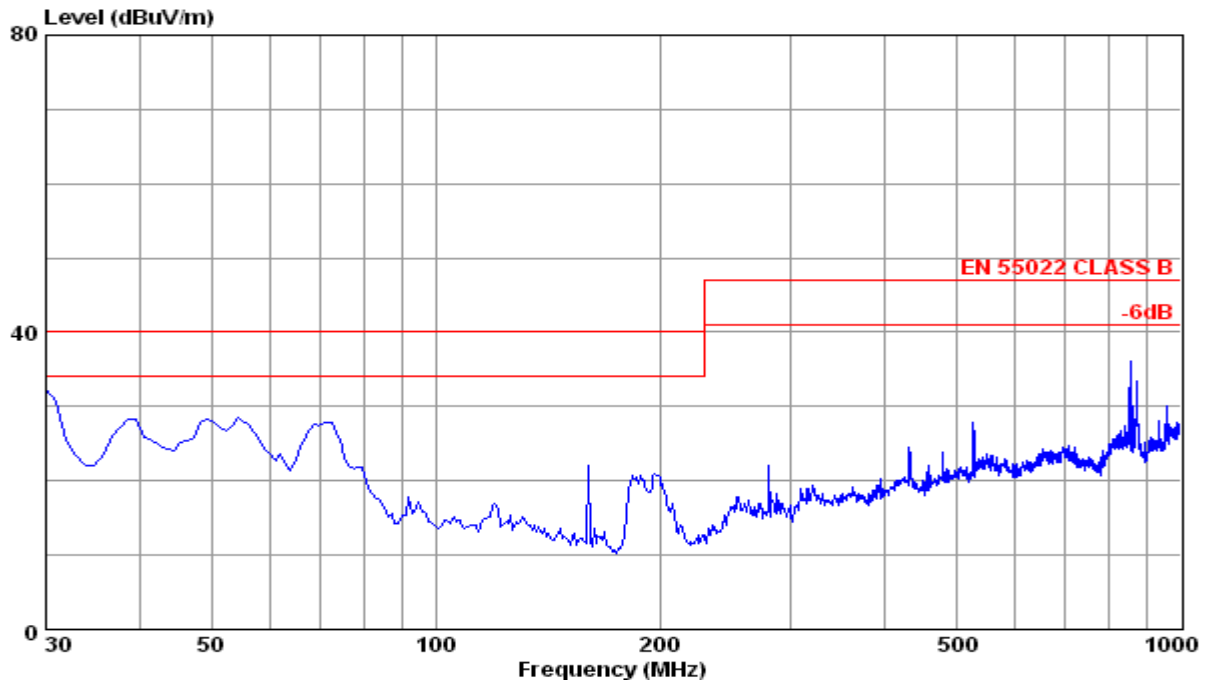

HORIZONTAL

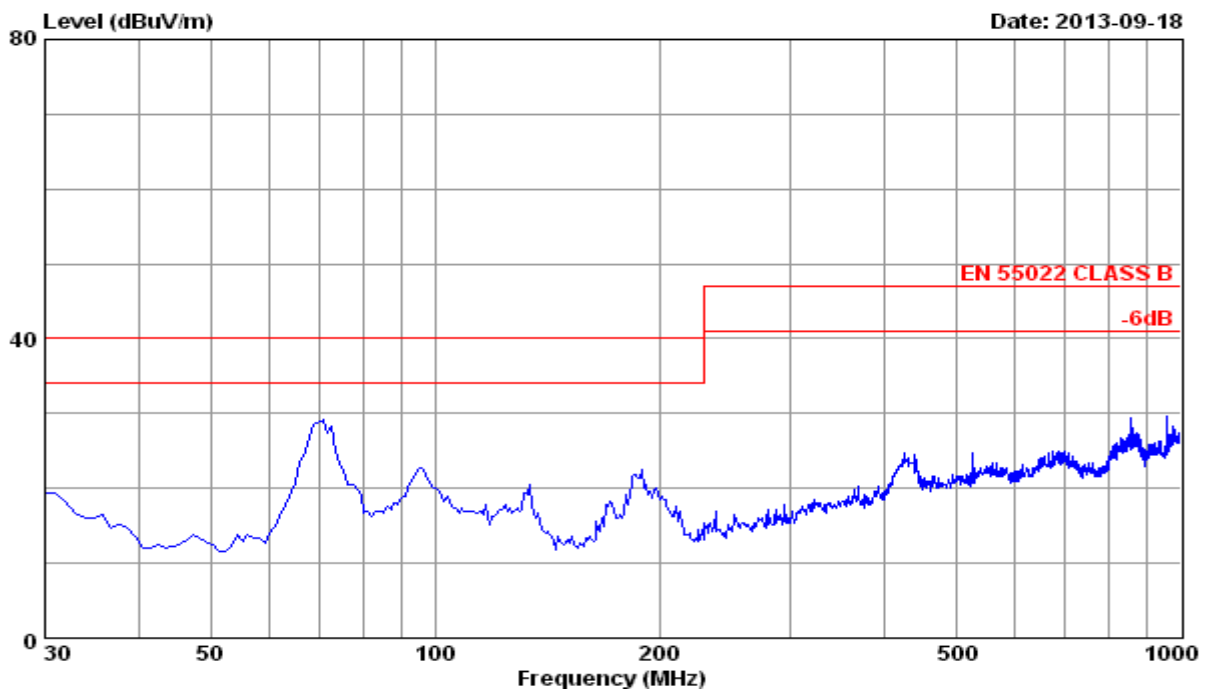

3.8 Protection Report

3.8.1 Protection Test – OVP,UVP,OTP

Test Condition: Ta=25°C, PVCC=AVCC=12V, Rload=8Ω (unless otherwise noted)

Items		Specification	Result
OVP	Over voltage threshold	over 22V then protection, no broken	22V
	Over voltage recovery threshold	return to 21.6V then recover, no broken	21.6V
UVP	Under voltage threshold	under 5.4V then protection, no broken	5.4V
	Under voltage recovery threshold	return to 5.8V then recover, no broken	5.8V
OTP	Over temperature protection	170°C±15 °C then protection, no broken	170°C
	Over temperature protection hysteresis	reduced 40°C then recover, no broken	40°C

3.8.2 Protection Test – Output Short Circuit Protection

3.8.2.1 Output Short Circuit Protection – output pin short to Vcc

Test Condition: Ta=25°C, PVCC=AVCC=12V, Rload=8Ω, audio input floating (unless otherwise noted)

Vcc	Items	Specification	Result
8V	pin OUTPL short to PVCC	OCP triggered, autorecovery triggered, no broken	PASS
	pin OUTNL short to PVCC	OCP triggered, autorecovery triggered, no broken	PASS
	pin OUTPR short to PVCC	OCP triggered, autorecovery triggered, no broken	PASS
	pin OUTNR short to PVCC	OCP triggered, autorecovery triggered, no broken	PASS
12V	pin OUTPL short to PVCC	OCP triggered, autorecovery triggered, no broken	PASS
	pin OUTNL short to PVCC	OCP triggered, autorecovery triggered, no broken	PASS
	pin OUTPR short to PVCC	OCP triggered, autorecovery triggered, no broken	PASS
	pin OUTNR short to PVCC	OCP triggered, autorecovery triggered, no broken	PASS
18V	pin OUTPL short to PVCC	OCP triggered, autorecovery triggered, no broken	PASS
	pin OUTNL short to PVCC	OCP triggered, autorecovery triggered, no broken	PASS
	pin OUTPR short to PVCC	OCP triggered, autorecovery triggered, no broken	PASS
	pin OUTNR short to PVCC	OCP triggered, autorecovery triggered, no broken	PASS

3.8.2.2 Output Short Circuit Protection – output pin short to GND

Test Condition: Ta=25°C, PVCC=AVCC=12V, Rload=8Ω, audio input floating (unless otherwise noted)

Vcc	Items	Specification	Result
8V	pin OUTPL short to PGND	OCP triggered, auto-recovery triggered, no broken	PASS
	pin OUTNL short to PGND	OCP triggered, auto-recovery triggered, no broken	PASS
	pin OUTPR short to PGND	OCP triggered, auto-recovery triggered, no broken	PASS
	pin OUTNR short to PGND	OCP triggered, auto-recovery triggered, no broken	PASS
12V	pin OUTPL short to PGND	OCP triggered, auto-recovery triggered, no broken	PASS
	pin OUTNL short to PGND	OCP triggered, auto-recovery triggered, no broken	PASS
	pin OUTPR short to PGND	OCP triggered, auto-recovery triggered, no broken	PASS
	pin OUTNR short to PGND	OCP triggered, auto-recovery triggered, no broken	PASS
18V	pin OUTPL short to PGND	OCP triggered, auto-recovery triggered, no broken	PASS
	pin OUTNL short to PGND	OCP triggered, auto-recovery triggered, no broken	PASS
	pin OUTPR short to PGND	OCP triggered, auto-recovery triggered, no broken	PASS
	pin OUTNR short to PGND	OCP triggered, auto-recovery triggered, no broken	PASS

3.8.2.3 Output Short Circuit Protection – output N pin short to P pin

Test Condition: Ta=25°C, PVCC=AVCC=12V, Rload=8Ω, audio 1kHz1Vpp sinewave differential input (unless otherwise noted)

Vcc	Items	Specification	Result
8V	pin OUTPL short to OUTNL	OCP triggered, auto-recovery triggered, no broken	PASS
	pin OUTPR short to OUTNR	OCP triggered, auto-recovery triggered, no broken	PASS
12V	pin OUTPL short to OUTNL	OCP triggered, auto-recovery triggered, no broken	PASS
	pin OUTPR short to OUTNR	OCP triggered, auto-recovery triggered, no broken	PASS
18V	pin OUTPL short to OUTNL	OCP triggered, auto-recovery triggered, no broken	PASS
	pin OUTPR short to OUTNR	OCP triggered, auto-recovery triggered, no broken	PASS

3.9 Reliability Report

3.9.1 Abnormal Power On Test

Test Condition: Ta=25°C, PVCC=AVCC=12V, Rload=8Ω (unless otherwise noted)

Items	Specification	Result
23Vcc power on	enter into OVP, no broken	PASS
5Vcc power on	enter into UVP, no broken	PASS
power on when air temperature exceeds 190°C	enter into OTP, no broken	PASS
power on when output short to GND	enter into OCP, no broken	PASS
power on when output short to Vcc	enter into OCP, no broken	PASS
power on when output N short to output P (audio 1kHz1Vpp sinewave differential input)	enter into OCP, no broken	PASS

3.9.2 High Temperature System Burn-in Test

Test Condition:

Ta=60°C, PVCC=AVCC=20V, Rload=8ohm*2, music input “异度狂欢”, peak output power >20W*2, duration 168hours(7days)

Test Result:

- The devices can operate normally after burn-in;
- All functions and all protections are in normal after burn-in;
- Output pin I-V characteristics are in normal after burn-in.

3.9.3 Low Temperature Cycle Power on-off Test

Test Condition:

Ta= -20°C, PVCC=AVCC=20V, Rload=8ohm*2, music input “异度狂欢”, peak output power >20W*2, power on-off 3000cycles, cycle time 1min

Test Result:

- The devices can on-off in each cycle;
- The devices can operate normally after test;
- All functions and all protections are in normal after test;
- Output pin I-V characteristics are in normal after test.

3.9.4 Maximum Output Power Burn-in Test

Test Condition:

Ta=25°C, PVCC=AVCC=15V, Rload=8ohm*2, Vin=1kHz sinewave, continuously output power = 13W*2, duration 48hours

Test Result:

- The devices can operate normally after burn-in;
- All functions and all protections are in normal after burn-in;
- Output pin I-V characteristics are in normal after burn-in.

Disclaimer

On-Bright Electronics reserves the right to make corrections, modifications, enhancements, improvements, and other changes to its documents, products and services at any time and to discontinue any product or service without notice. Customers should obtain the latest relevant information before placing orders and should verify that such information is current and complete.

This document is under copy right protection. Non of any part of document could be reproduced, modified without prior written approval from On-Bright Electronics.